

Kneeling Garden Cart Build Manual



Product Information

Name: Rolling Kneeler Cart

Model No.: 001

Manufacturer: MSU Capstone DG11 – Connor Mackenzie, Hannah Crist, Jack Darrow, Kaden Swierkos, and Ryan Harth, for Michigan AgrAbility

Date: December 2024

Table of Contents

Introduction.....	3
Materials and Tools Needed	3
Assembly.....	8
Suggested Improvements	18

Introduction

The following instructions manual outlines the materials needed and assembly instructions for creating a kneeling garden cart with a chest strap designed to mitigate back pain while navigating through garden rows to do various tasks. This manual provides instructions for non-motorized and motorized versions of the cart, both versions complete with a steering assembly. Note that this is a base model and can be adjusted easily to fit specific needs. The cart's frame is built from 80-20 extrusion, making it highly adjustable for users. Key specifications for the cart can be found below.

Kneeling Garden Cart Design Specifications

	Motorized	Non-motorized
Minimum Cost to Build	\$850	\$550
Dimensions	44" long x 24" wide x 34" tall	44" long x 24" wide x 34" tall
Weight (load)	350lb	350lb
Recommendation		
Speed	0.34 ft/s	N/A

Materials and Tools Needed

Materials Needed:

The following section lists all items needed for the cart's assembly, with links. These are links to primary seller's websites, but it is encouraged to shop around as less expensive options are surely available.

Note that links are provided for informational purposes only and do not constitute endorsement by Michigan State University or MSU Extension.

*Quantities are listed by how many are needed in the design, regardless of seller pack size

Materials and Tools Needed				
Item	Specifications	Qty	Link	Comments
Steering				
Steering Spindle	Spindle & Bracket Set Axle: 5/8-18 Length: 3-3/4" 5/8" -18 Kingpin	2	AZUSA	
Ball Joint - Right Hand Thread	Shank Thread Size: 3/8"-24 (fully threaded, right-hand male) ID (Inner Diameter): 3/8" Thread Length: 1 1/4"	2	McMaster-Carr	
Ball Joint - Left Hand Thread	Shank Thread Size: 3/8"-24 (fully threaded, left-hand male) ID (Inner Diameter): 3/8" Thread Length: 1 1/4"	2	McMaster-Carr	
4" Turn Buckle Rod	Overall Length: 4". Thread Size: 3/8"-24 (matches the previous shank thread size). Thread Length: 1"	2	McMaster-Carr	
12" Wheels	5/8" Center Bearing Hub: 2.1" Tire width: 3.5"	4	Amazon	*3 needed for the motor option
Angled flat Bracket	135 Degree Flat Bracket Total Size: 3.45" x 3.45" x 1.02"	1	Amazon	
Handle	Thread Size: 3/8" 16 Stud Length: 5/8" Handle Length: 3 1/8"	1	McMaster-Carr	
Threaded Rod	Length: 2 ft Thread Size: 5/8"-11	1	McMaster-Carr	

Frame, Accessories, and Fasteners				
Soft Foam Kneeling Pad	Thickness: approx. 1.5"	1	Home Depot	Coated/closed cell preferred
40mmx40mm T Slot	Final Lengths Needed: (2) 7" (2) 10" (4) 24" (2) 36"	n/a	McMaster-Carr	Source stock but ensure lengths specified are possible
Corner Brackets	Corner brackets with gusset designed for 4040 t slot	16	McMaster-Carr	
Eyebolts	Thread Size: M8	2	McMaster-Carr	
Chest Strap	Designed as a wheelchair restraint, adjustable with buckles	1	Amazon	
Tee-Brackets		4	McMaster-Carr	
Velcro	Length: 4 ft	1	Amazon	
Carabiners for Chest Strap Connection	Size: 3"	2	Amazon	
Plywood Base	15" x 22"	1		
T nuts		66	McMaster-Carr	Includes t nuts needed for brackets
M8 Bolts	Length: 12-14mm	64	McMaster-Carr	Includes bolts needed for brackets
Nuts	5/8" (for fixing wheel on axle)	4	McMaster-Carr	
Screw	3/8", length = 2.5" for steering spindle	2	McMaster-Carr	
Screw	3/8" x 1" (for steering)	2	McMaster-Carr	
Screw	1/2" length = 4" for steering	1	McMaster-Carr	

Nuts	3/8"(for steering)	4	McMaster-Carr	
Washer	3/8" (for steering)	4	McMaster-Carr	
Nuts	1/2" (for steering)	3	McMaster-Carr	
Washer	1/2" (for steering)	2	McMaster-Carr	
Screw	5/16" x 1.5" (for steering)	1	McMaster-Carr	
Screw	5/16" x 0.75" (for steering)	2	McMaster-Carr	
Nut	5/16" (for steering)	3	McMaster-Carr	
Motor Option ONLY				
Chain	36" 35 Chain	1	McMaster-Carr	
Motor	<p>12V Brushless DC</p> <p>Shaft: 8mm diameter, 1 inch (25.4mm) long, flat</p> <p>8.4 N-m (6.2 ft-lb) torque at 35 RPM</p> <p>60mm x 60mm square front with 4 M4 threaded holes for face mounting</p> <p>2.5 in (64mm) width, 4.75 in (121mm) length, 1.75 in (44mm) depth</p> <p>Accepts 115v ac or 230v ac</p> <p>Speed adjustment via potentiometer</p>	1	MakerMotor	

Sprocket for Tire	35 chain compatible 60 tooth (downsize for higher speeds)	1	Amazon	Can adjust chain # as long as both sprockets are compatible
Drive Wheel	Diameter: 12" 5/8" ID bearing Built-in flange for sprocket	1	Go Power Sports	
Sprocket for motor	11 teeth, 35 chain compatible	1	McMaster-Carr	
Motor Switches	12 V 30 A On Off SPST 2-pin toggle switch	2	Daier	
Battery & Charger	12 V 15 Ah LiFePO4	1	Amazon	See battery notes
Plywood battery base	5" by 7" -size for battery	1		
Sheet Metal	For motor and switch mounting, stabilizing bar (steel preferred)	n/a		
M4x20mm Screw	For mounting of the motor into manufactured sheet metal	4	McMaster-Carr	
Screw	3/8" by 1/2" (for securing sprocket to drive wheel)	4	McMaster-Carr	
Nut	3/8" (for securing sprocket to drive wheel)	4	McMaster-Carr	
Wire Connectors		2	Amazon	

Extra Wire	Use a gauge close to the other wires	4		
------------	--------------------------------------	---	--	--

Battery Notes:

The motor chosen draws 2.5A, so select the battery charge based on the hours of operation needed, see the table below:

Battery Charge (Ah)	Hours / Charge
15	6
20	8
30	12
50	20

Sprocket Notes:

The sprockets detailed in the BOM produce the following:

- 5.45:1 Gear Ratio
- 0.34 ft/s speed
- To increase top speed, decrease the size of the sprocket set on the drive wheel.

Tools Needed:

Ideal Tools	Minimum Required Tools
Drill Press	Hand Drill
Mill	Hand Drill with Jig
Band Saw	Hack Saw
Standard and Metric Wrench Set	2 Adjustable Wrenches

Assembly

This section shows assembly instructions for the cart, including CAD model views to aid in understanding.

1. Cut pieces of aluminum extrusion into the following lengths using a bandsaw
 - a. Sand edges to smooth
 - (2) 7"
 - (2) 10"
 - (4) 24"
 - (2) 36"
2. Create the following holes on the aluminum lengths (all dimensions are in inches)
 - a. Using mill, drill press or hand drill with [Jig](#)

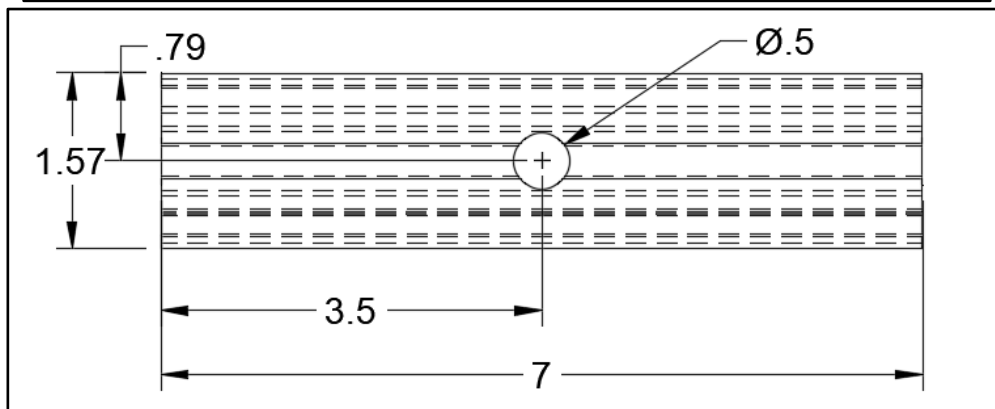
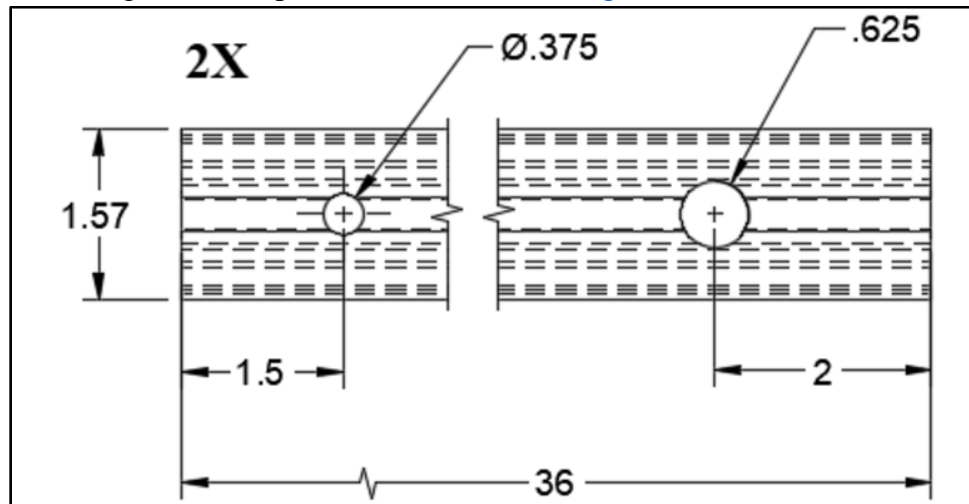

3. Assemble Lower Frame
 - a. Connect 7"[2] and 36"[2] aluminum extrusions using T-nuts[16], and brackets[8]
 - b. Connect Plywood using T-nuts[4]
 - c. Connect Upper frame brackets[4] using T-nuts[12]

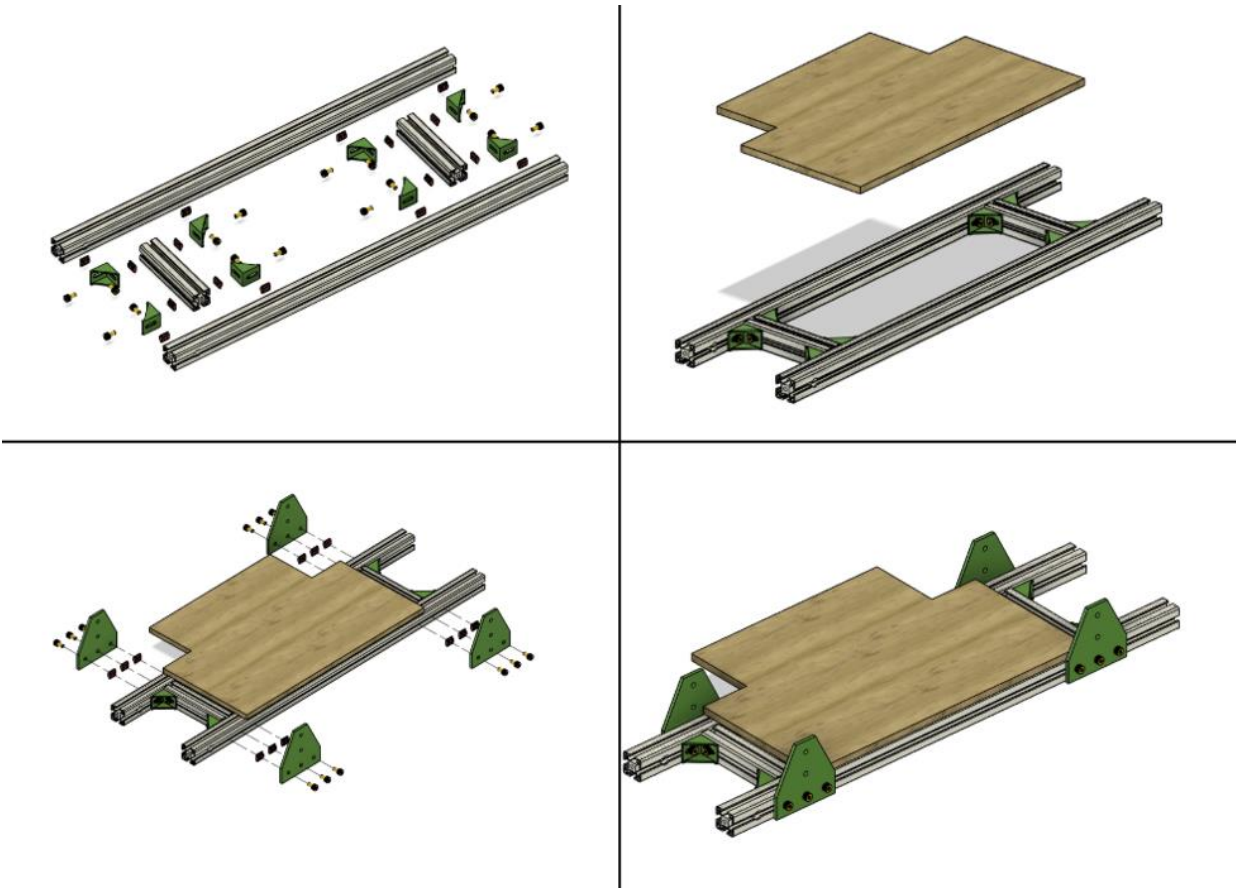

4. Assemble Upper Frame and Install

- a. Connect 24" and 10" Aluminum Extrusions using corner brackets[8] M8 bolts[16] and T-nuts[16]

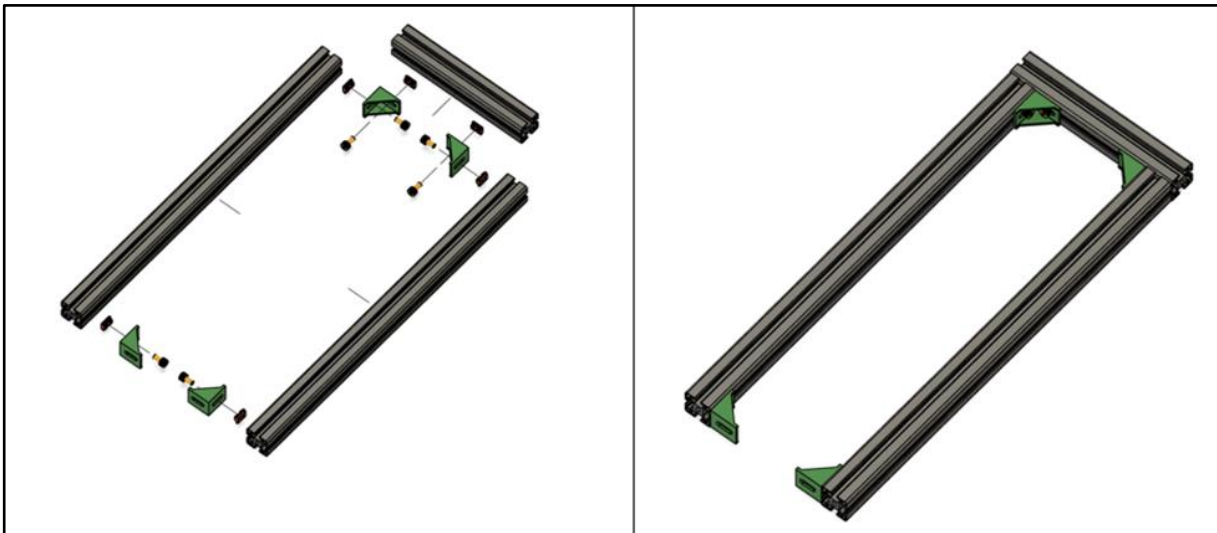

- b. Connect upper frame assemblies to the lower frame, using corner brackets [8] and tee brackets [4] with M8 bolts [36] and T-nuts[36]

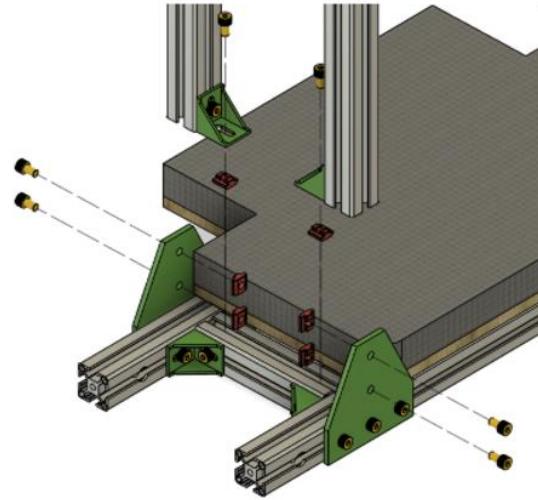
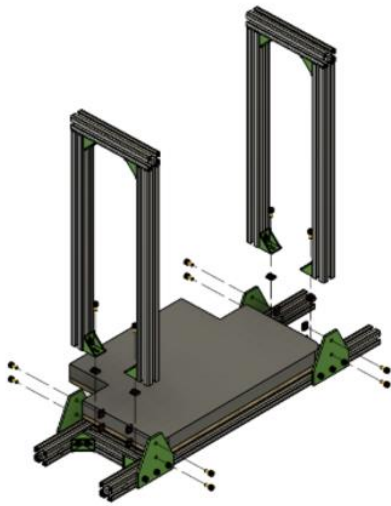

5. Assemble Back wheels

- a. Slide the $\frac{3}{8}$ in axle through the holes in the 36" aluminum extrusion and secure with $\frac{3}{8}$ inch nuts[2]
- b. Secure wheels using $\frac{3}{8}$ " nuts[4]

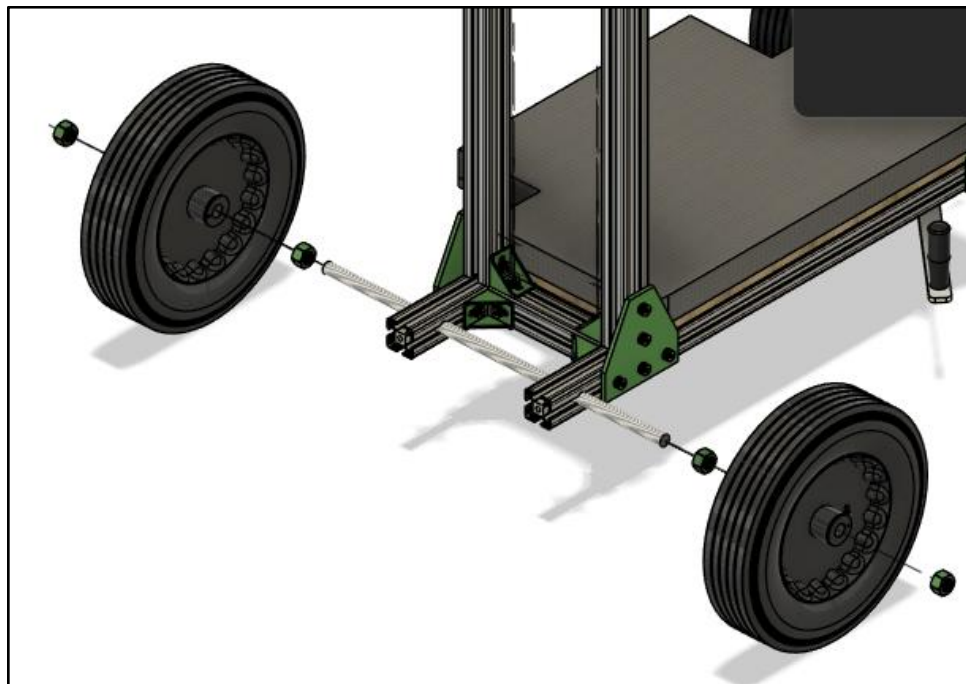

6. Assemble Steering Assembly

- a. Attach 135 degree bar to Aluminum extrusion using $\frac{1}{2}$ inch bolt and nuts
- b. Drill hole in $\frac{3}{8}$ inch hole in U bar wheel bracket
- c. Insert $\frac{3}{8}$ x 2.5 in bolt into and attach wheels using spindle assembly, spacer and $\frac{5}{8}$ nut

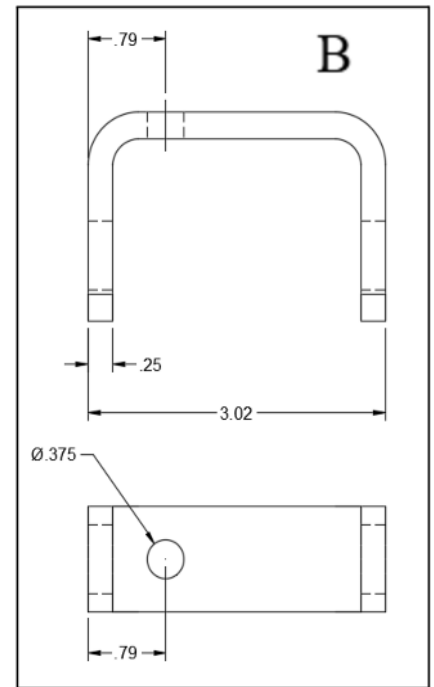
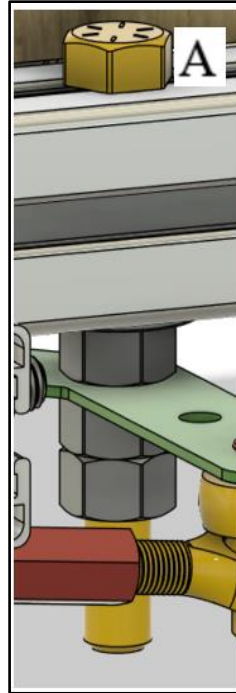
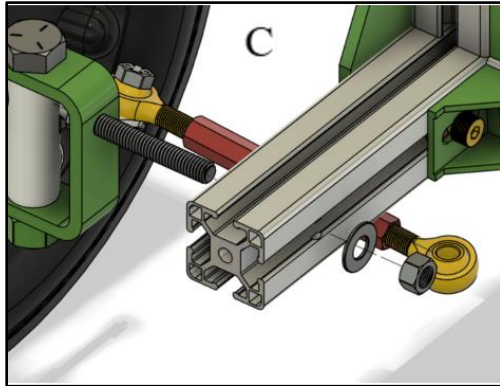

- d. Attach the turnbuckle rods to steering spindles using $\frac{3}{8}$ x 1 inch nut and bolt, attach both rods to the 135 degree bracket using $\frac{1}{4}$ x 4 inch screw and nut
- e. Attach handle bar and handle to 135 degree bracket using $\frac{1}{4}$ x .5 inch screws and nuts

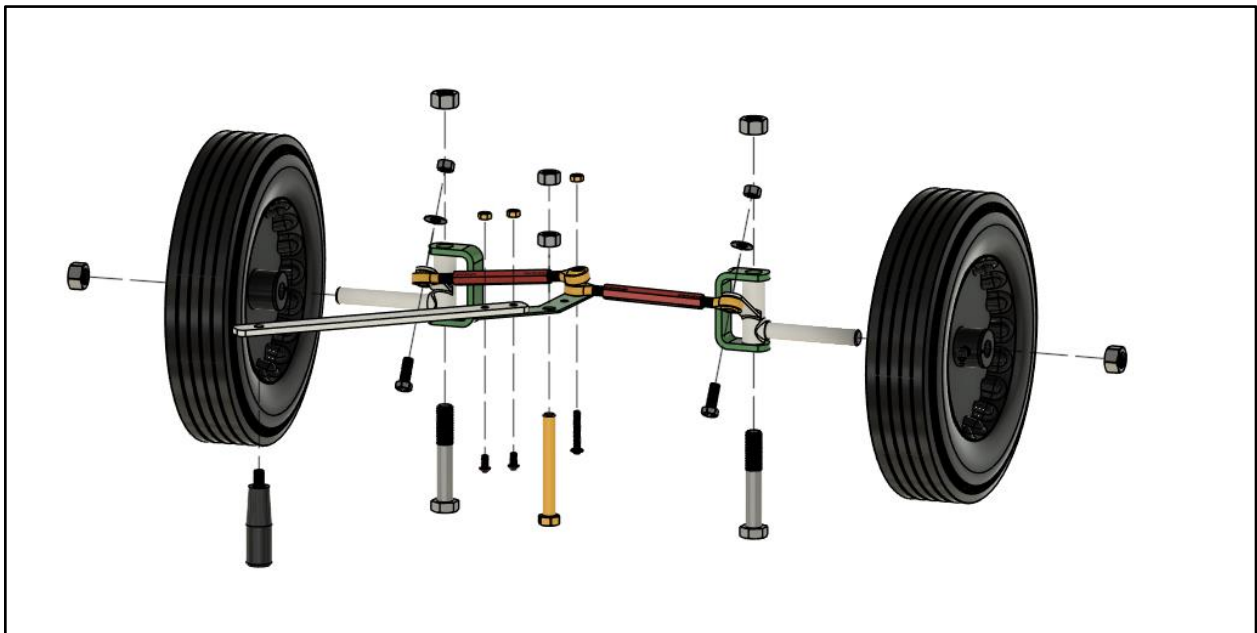

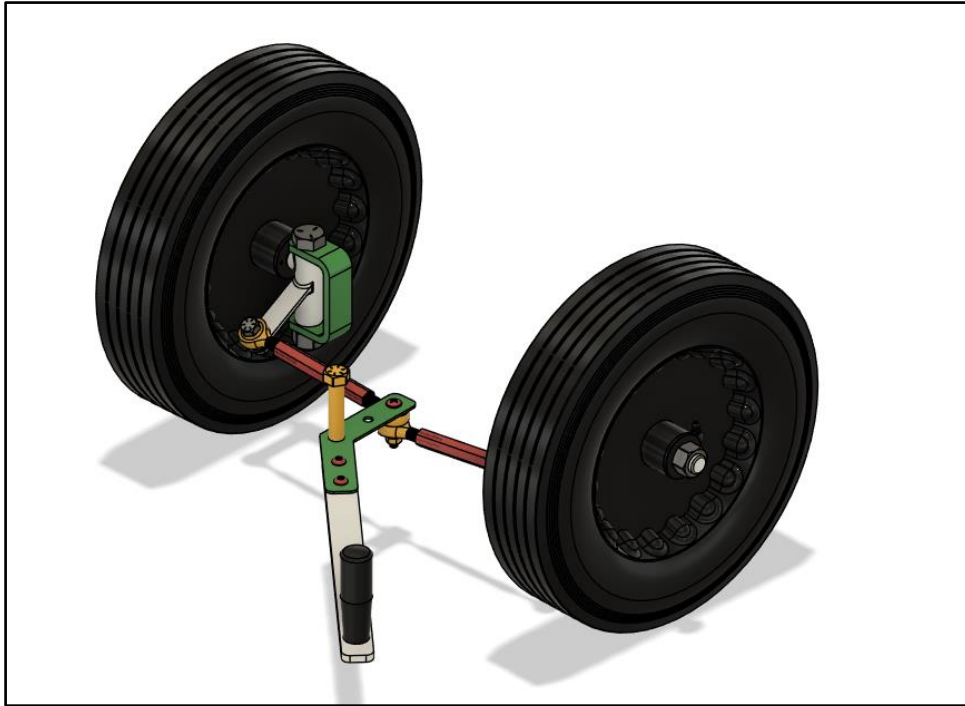

7. Assemble Accessories

- a. Cut foam padding in the same shape as plywood using handsaw
- b. Using velcro, attach the pad to the plywood
- c. Loop carabiners through the chest strap adjustment loops
- d. Set up the eyebolts [2] on the top or side of upper frame and screw them into t nuts[2]
- e. To prevent the eyebolt assembly from sliding forward out of the t slot, tighten a set of M8 bolts and t nuts [2 each] in front of eyebolt assembly
- f. Hook the chest strap carabiners into the eyebolts and adjust for comfort



8. Motor Assembly- optional
 - a. Create motor mount plate from sheet metal

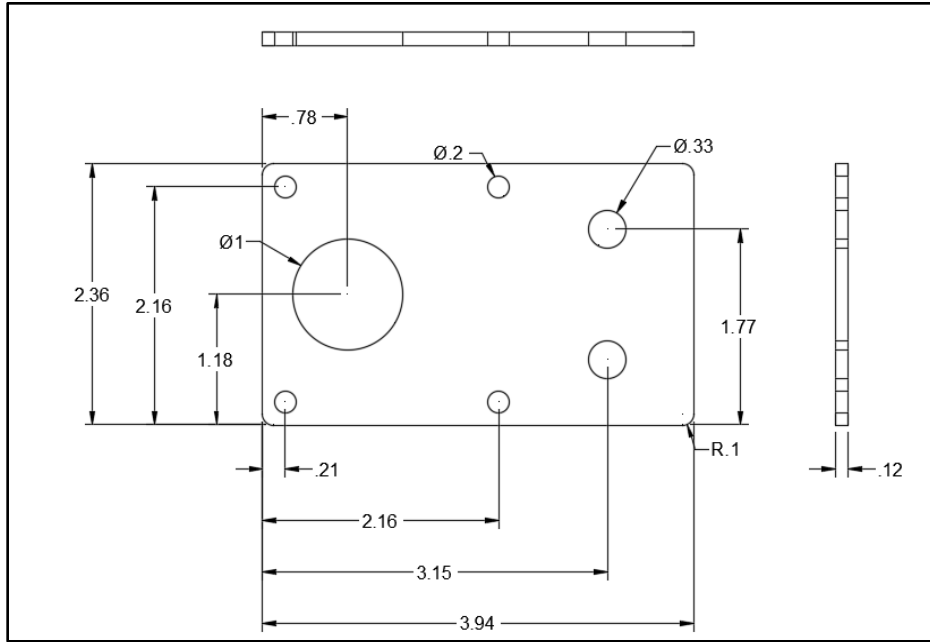

- b. Fix plate to the t slot at desired height with M8 bolts[2] and t nuts[2] and to the motor with M4 bolts [4]
- c. Place the motor sprocket onto the shaft and secure it with set screws

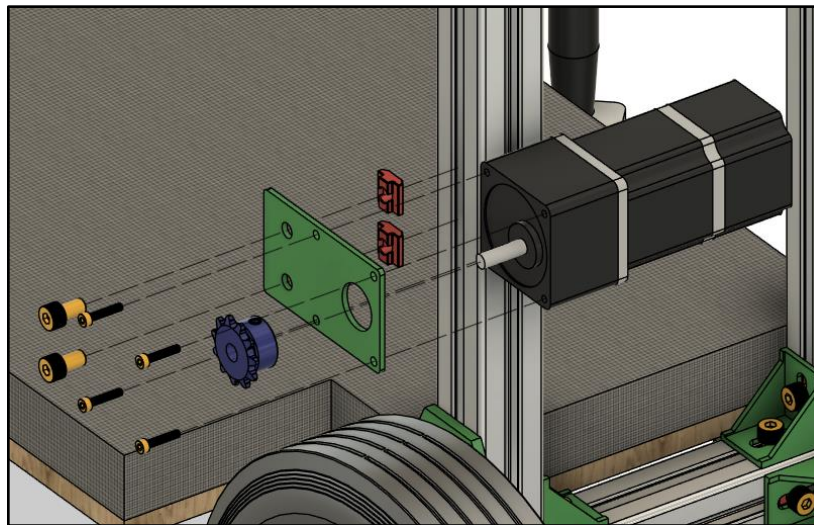

- d. Fix wheel sprocket to drive wheel with bolt pattern, using $\frac{3}{8}$ " by $\frac{1}{2}$ " bolts [4] and $\frac{3}{8}$ " nuts[4]

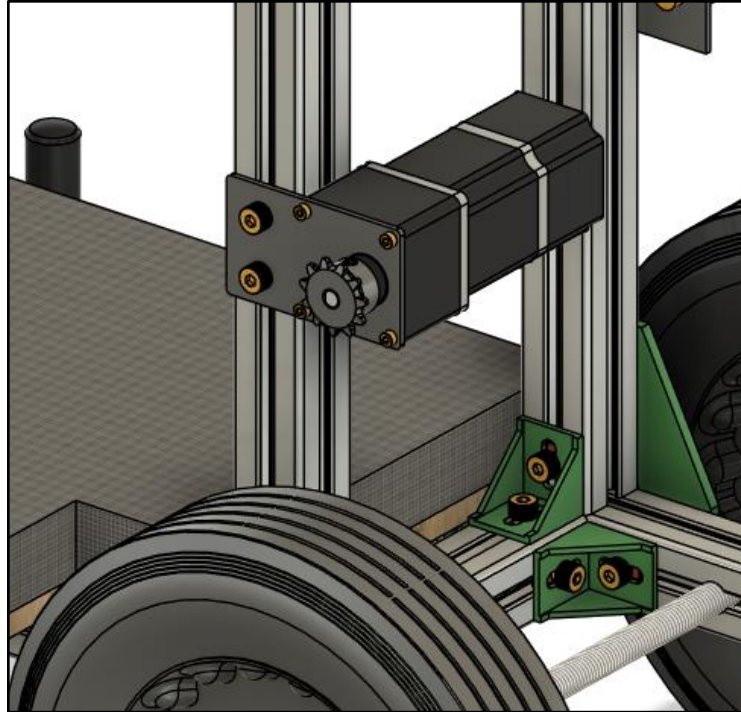

- e. Attach the chain to both sprockets, shortening if needed
 - f. Move the motor mount vertically on the t slot to tension the chain as needed
 - g. Cut a plywood base for the battery
 - h. Connect the plywood base into the t slot with M8 bolts [4] into t nuts[4] (sitting on the back end of the cart beneath the motor)
 - i. Attach the battery to the plywood with velcro
9. Wiring Guide
- a. Have a way to attach wires together (soldering is recommended)
 - b. Wire together the potentiometer and motor following the diagram below
 - c. Attach provided clamps to the ends of wires to connect to the terminals of the switches
 - d. Connect the other ends of the switch wires to their respective wires as shown in the diagram
 - e. Connect the battery cables on the motor to the battery with the connectors that fit the battery terminals

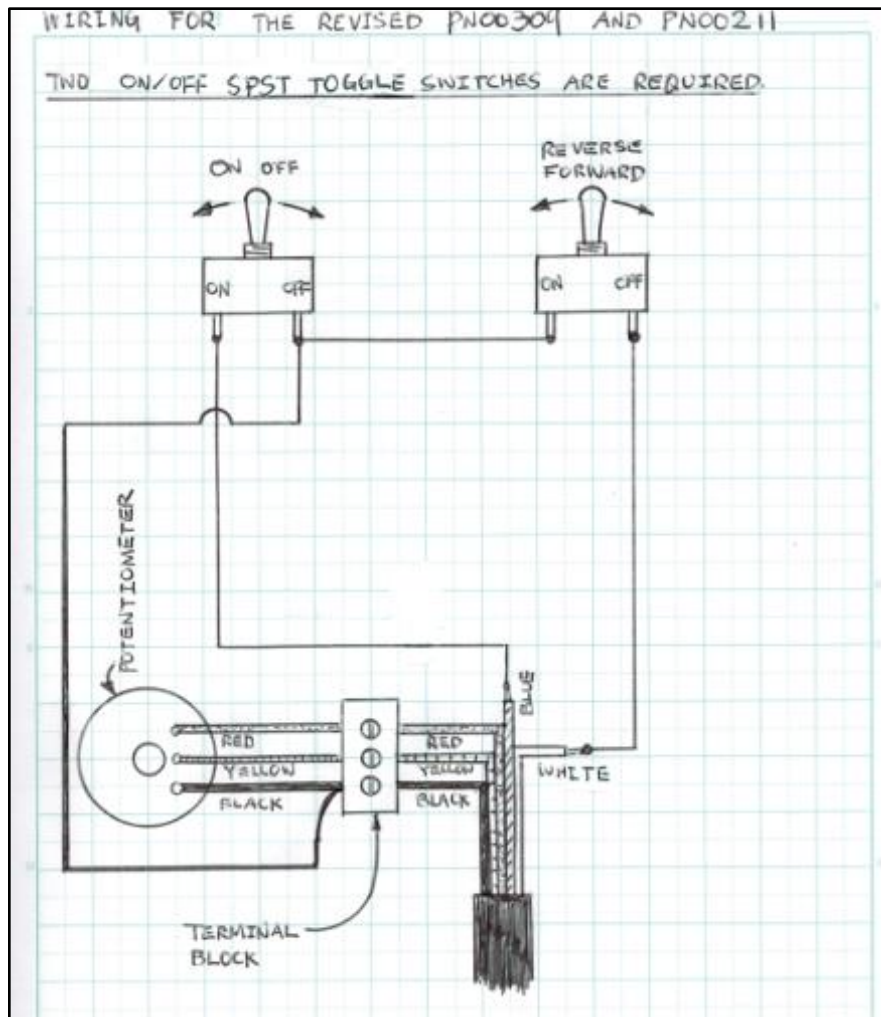

10. Switch Plate Assembly

- Manufacture switch plate to fit the drawing shown using sheet metal
- Mount switch plate to Aluminum extrusion using M8 bolts and T-nuts
- Secure plate to Aluminum extrusion using M8 bolts and T-nuts
- Unscrew nut from the switches, slot switches through hole and reattach nut
- Gently pull off the potentiometer dial, unscrew nut, slot through hole and reattach

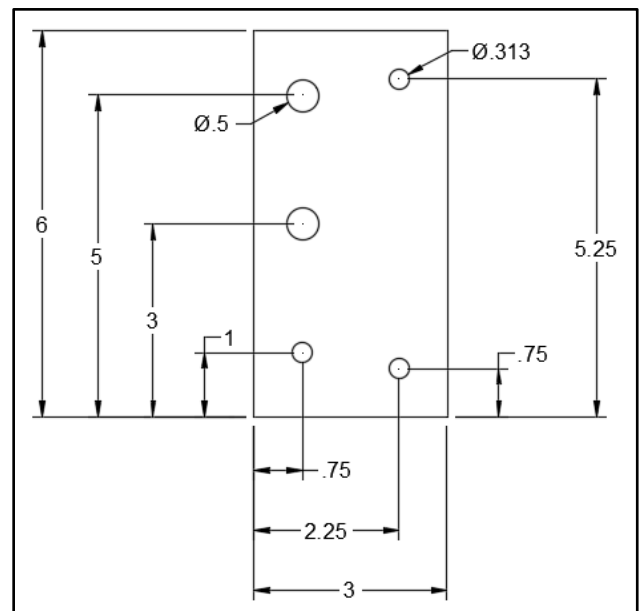

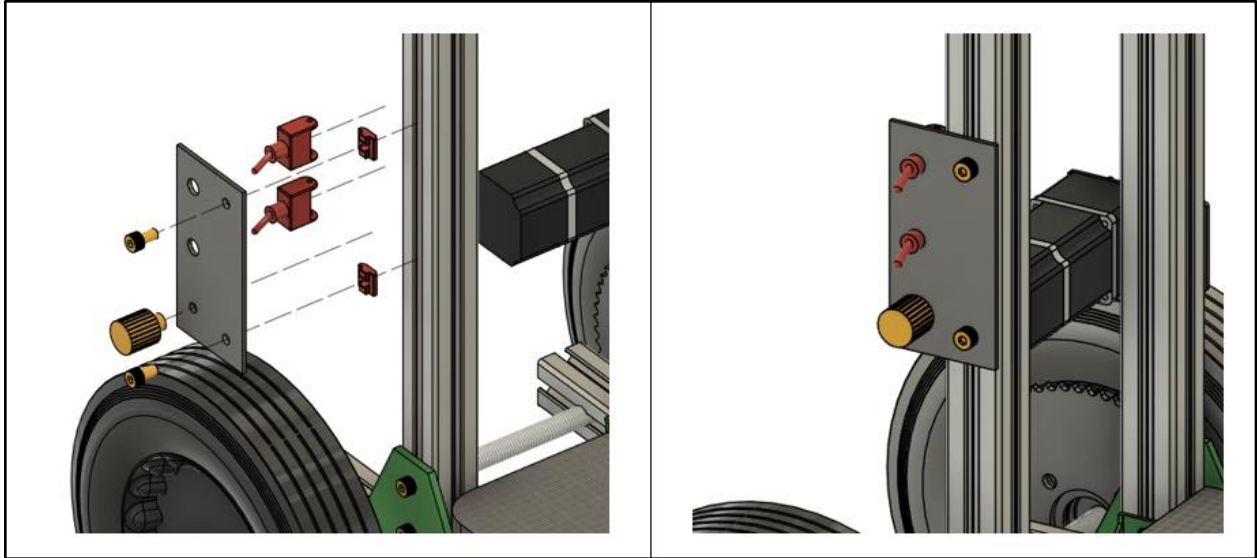

Additional Accessories

- An STL file can be found online with the instructions containing a chain guard which can be 3D printed

Suggested Improvements

Weatherproofing solution for motor assembly

- Plastic housing with holes for wiring
- Shrink wraps for wires

If the motor option is followed, the rear wheels can't disengage, so it can't be pushed/rolled idly.

Possible solutions to this issue include:

- Producing a dolly-like device that can lift the rear wheels off the ground
- Smaller, fold-down wheels
- Using a belt drive
- Neutral option for motor
- Increasing the speed capabilities of the cart so it can be driven

Michigan State University Extension and AgrAbility are not responsible for loss of property, personal injury, death, or other damages caused by this product

This project was supported by the AgrAbility Competitive Program of the USDA National Institute of Food and Agriculture (NIFA), grant number 2022-41590-38121.

MSU is an affirmative-action, equal-opportunity employer, committed to achieving excellence through a diverse workforce and inclusive culture that encourages all people to reach their full potential. Michigan State University Extension programs and materials are open to all without regard to race, color, national origin, gender, gender identity, religion, age, height, weight, disability, political beliefs, sexual orientation, marital status, family status or veteran status. Issued in furtherance of MSU Extension work, acts of May 8 and June 30, 1914, in cooperation with the U.S. Department of Agriculture. Quentin Tyler, Director, MSU Extension, East Lansing, MI 48824. This information is for educational purposes only. Reference to commercial products or trade names does not imply endorsement by MSU Extension or bias against those not mentioned.